

This Field Operations Guide contains specific information on technical rescue procedures.

THIS GUIDE IS NOT ALL INCLUSIVE!

It is intended to be used as a tool for training and for quick field reference. Refer to current training manuals and your department policies for detailed explanations. There is no substitute for regular, quality, hands-on training by a qualified instructor.



The techniques and procedures illustrated in this guide follow NFPA standards and OSHA regulations as much as possible. This guide can be used by rescuers at all skill levels but was specifically developed for fully qualified technical rescue technicians. Special operations are inherently dangerous and serious injury or fatality may result from improper performance of these techniques. The author accepts no responsibility for damage, loss, injury or death resulting from information contained in or omitted from this guide.

Thanks to the Phoenix Fire Department and everyone who helped make this guide possible. Special thanks to my friend Ron Jamison for helping to write this guide, Kathy Darrow for editing and to George Drees, Ken Phillips and Jim Frank for great ideas and input.

This guide is dedicated to all those people who go the extra inch every day to make themselves better rescuers.

This handbook is based on the Phoenix Fire Department and Arizona State Fire Marshall's Office technical rescue programs.

ISBN 0-9675238-4-2

Third Edition October 2003

Illustrations and text copyright ©1999-2003 Tom Pendley. All rights reserved. No reproduction, storage or transmission without written permission of the author. Published by Desert Rescue Research. Photos by Tom Pendley and Glenn Speight. Cover art, text layout and design by Glenn Speight.

Contents

Key procedures in red

NFPA Standards	2	Confined Space Rescue	
Risk Management	3	Con Space Command Checklist	58
Incident Management	4	Con Space Definitions	60
Time Management	6	Con Space Entry Safety Checklist	61
Rope Rescue		Personal Protective Equipment	62
Rope Command Checklist	7	Supplied Air Station Operation	63
Personal Protective Equipment	8	Remote Air Cart	64
Terrain Types	9	Communication Position	65
Mountain Rescue Decision Tree	10	Intercom	66
Basic Life Safety Knots	11	Atmospheric Monitoring	67
Load Releasing Hitch (LRH)	15	Ventilation	68
Personal Purcell Prusik System	16	Extrication Device	72
Self Rescue	18	Rescue Tripod and Winch	73
Patient Packaging	19	Winch Cable Setup	75
Low Angle Evacuation	20	Rescue Tripod and Pulley System	76
Anchor Systems	21	Aerial Apparatus	77
Back-Tie Anchors	23	Swiftwater Rescue	
Directional Anchors	24	Swiftwater Command Checklist	79
Structural Anchors	25	Equipment	80
Fixed Belay for Edgemen	26	Swiftwater Rescue Comm	82
Edge Protection	27	Swiftwater Hazards	83
Tandem Prusik Belay Setup	28	Safe Swimming Position	84
Technical Evacuation	30	Shore-Based Rescue: Reach	85
Technical Evacuation Commands	33	Shore-Based Rescue: Throw	87
Technical Evacuation Lower	34	Shallow Water Crossing: Wade	89
Technical Evacuation Raise	35	Boat Operations: Row	91
Steep Angle Evacuation	36	Boat on Highline	94
High Angle Litter Rigging	37	Strong Swimmer Rescue: Go	97
High Angle Evacuation	38	Helicopters and Swiftwater	100
Mechanical Advantages	39	Trench Rescue	
Ganged Mechanical Advantage	41	Trench Command Checklist	101
Conversion from Lower to Raise	42	Trench Incident Site Setup	103
Knot Passing	43	Trench Definitions	104
Mid-Face Litter Scoop	46	Trench Hazards	105
Rescue Pick-off	48	Hydraulic Speed Shore System	106
Rescuer Based Pick-off	50	Pneumatic Shore Placement	109
Team Based Pick-off	55	Timber Shore Step-by-Step	111

Contents

Key procedures in red

Structural Collapse

Structural Collapse Checklist	116
Task Level Checklist	117
SAR Marking System	119
Cut Station	121
Material Capacities and Weights	123
Airbag Operation	124
T Spot Shore	125
Ellis Clamps	126
Two Post Vertical Shore	127
Laced Post Shore	128
Alternate Door/Window Shore	129
Standard Door / Window Shore	130
60° and 45° Solid Sole Rakers	131
Flying Raker	134
Sloped Floor Shoring	135

Helicopter Operations

Helo Ops Command Checklist	139
Helicopter Flight Risk Score	140
Landing Zone Safety	141
Rescuer Safety	142
Power On Insertions	143
Longline Use Decision Tree	145
Longline/Short Haul Procedures	146
Capewell Release Mechanism	148
Litter Rigging for Longline	149
Emergency Procedures	150
Sling Loading Equipment	150

Rescue Medical Situations

Crush Syndrome	151
Suspension Trauma	152
Hypothermia	153

Appendices	154
------------	-----

Trench Rescue Command Checklist

Phase I: Size-up

- Primary assessment
 - Secure witness or competent person
 - Identify immediate hazards
 - Location, number, condition of victims
 - Rescue or recovery
- Secondary assessment
 - Trench collapse yes no
 - Proper equipment and personnel on scene
 - Additional resources necessary: ventilation, shoring, retrieval system

Phase II: Pre-Entry Operations

- Make general area safe
 - Traffic control
 - Crowd control
 - Heavy equipment shut down
 - Establish zones: hot, warm, cold
- Make rescue area safe
 - Establish lobby control accountability
 - Secure hazards: gas, electric, utilities
 - De-water trench
 - Monitor atmosphere
 - Ventilate

Phase III: Rescue Operations

- Make trench lip safe
 - Assess spoil pile
 - Approach from ends
 - Place ground pads
- Make trench safe
 - Access/egress ladders less than 50 ft. (15m) apart
 - Protective system; sloping, hydraulic, timber, other
 - Create safety zones
 - Remove dirt: extend safety zones.

- Victim assessment.
 - Treatment in trench, see crush syndrome (p.151)
 - Patient packaging
 - Retrieval system/extrication
 - Transfer to treatment sector

Phase IV: Termination

- Personnel Accountability Report (PAR)
- Remove tools and equipment
- Remove protective system
 - Last in - first out
- Secure scene
- Consider debriefing
- Call OSHA

Soil Types

Type A: cohesive soils with an unconfined, compressive strength of 1.5 ton/sq. ft. (tsf) (144 kPa) or greater (most stable)

Type B: cohesive soil with an unconfined compressive strength greater than 0.5 tsf (48 kPa) but less than 1.5 tsf (144 kPa)

Type C: cohesive soil with an unconfined compressive strength of 0.5 tsf (48 kPa) or less (least stable)

Unconfined compressive strength: the load per unit area at which a soil will fail in compression.

In a rescue situation, soil types are considered to be worst case scenario (type C) and shoring should be constructed accordingly.

Trench Incident Site Setup

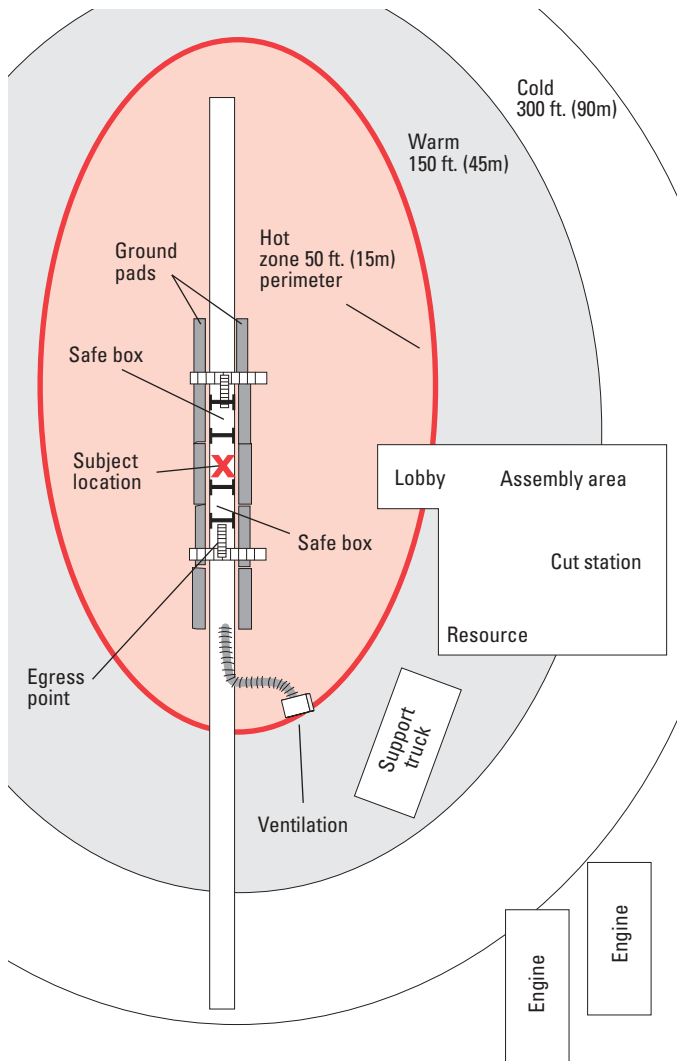

Trench Definitions and OSHA Regulations **A**

- Any trench 4 ft. (1.2m) deep or greater must have a means of egress within 25 ft. (7.5m) of any worker
- Any trench with a hazardous atmosphere or a potential hazardous atmosphere that is 4 ft. (1.2m) deep or greater must be monitored prior to employee entry
- An occupied trench 5 ft. (1.5m) deep or greater must have an approved protective system to protect employees from cave-ins
- Protective systems shall be placed from the top working down and removed from the bottom working up so as to protect the employee during construction or removal
- During rescue operations all soil should be considered type C and protective systems and practices shall be used accordingly
- *The timber shoring system illustrated in this guide is designed by a registered professional engineer for the Phoenix Fire Department, and any agency wishing to use this system or a similar system must establish an agreement with a registered professional engineer*

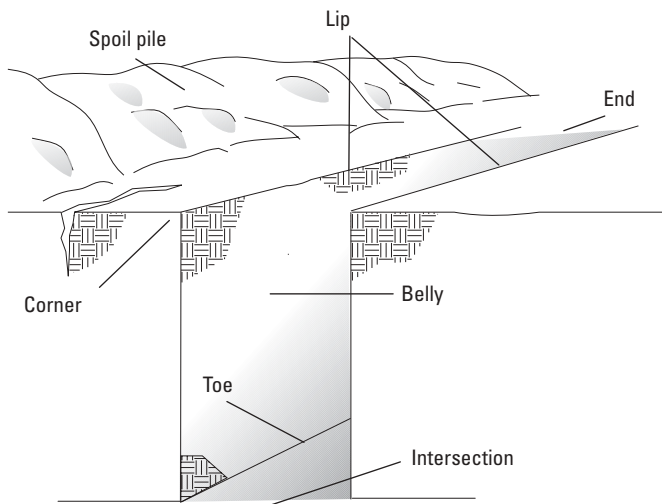

Trench Hazards and Causes of Collapse

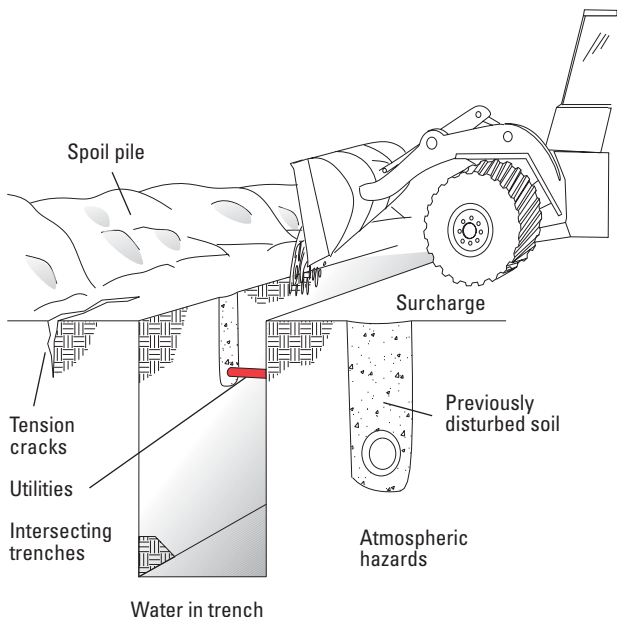

Remember:

- Soil weighs approximately 100 lbs./ft³ (50kg/.5m³) per cubic ft. and 3000 lbs./yd³ (1400kg/m³)
- If an initial collapse occurred, secondary collapse is highly likely
- Consider the possibility of a hazardous atmosphere in a trench
- Exposed utilities should be supported in place

✓ Do not enter an unprotected trench for any reason!



Hydraulic Speed Shore® System

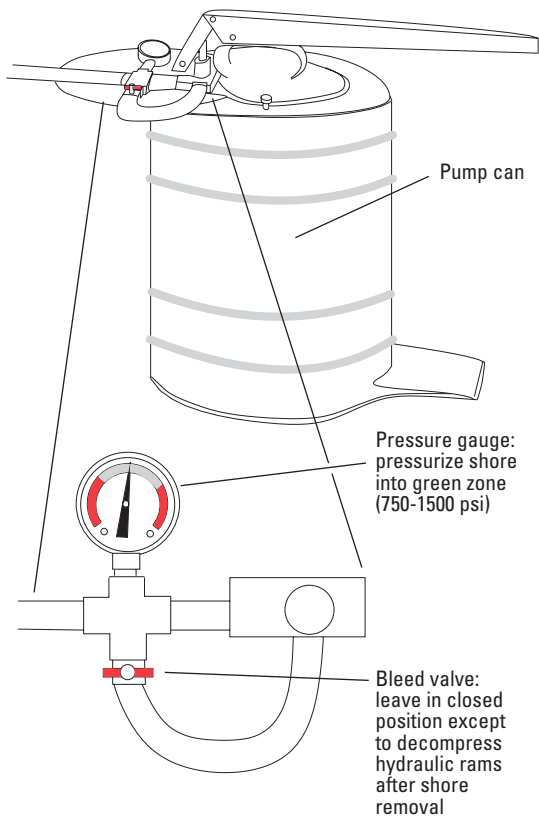

- ✓ Pressurize all shores to a consistent pressure within the green zone.

Speed Shore Installation

1. Measure trench width and depth and then select suitable shore.
2. Lower two sheets of form sheeting into trench at designated location and hold.
3. Connect pump can pressure hose to inlet port on upper cylinder assembly.
4. Place pump can bleed valve in closed position.
5. Attach T handle to handle on lower vertical rail.
6. Grasp handle of other vertical rail and lower shore into trench.
7. Release upper vertical rail and let it drop into position.
8. Hold shore in position and pump up to operation pressure (green).
9. Do not open bleed valve.
10. Remove hose from coupling with end of T handle.

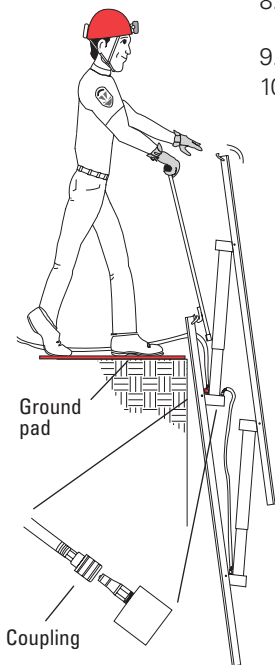

For irregular or sloping walls a single cylinder rescue shore can be used

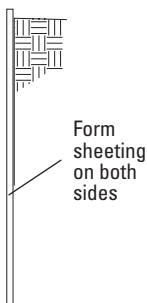

- ✓ Avoid the use of hydraulic shores near trench intersection corners.



Aluminum Hydraulic Speed Shore

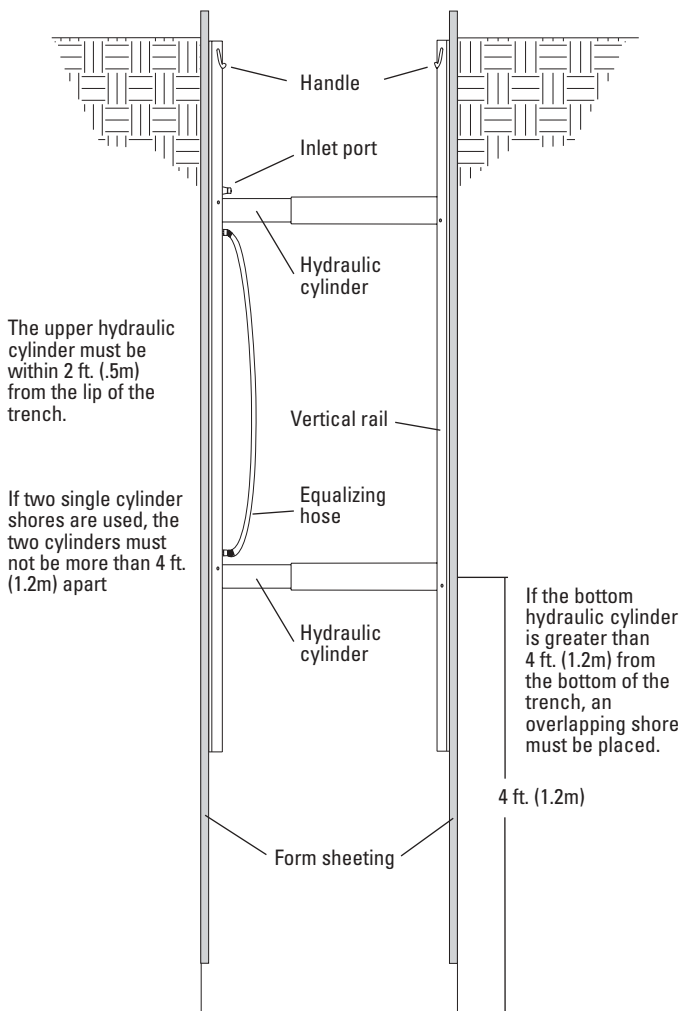

Pneumatic Shore Placement

Pneumatic shores can be properly installed from outside the trench initially. Try to protect as much of the trench as possible using this technique before entering.

1. Clean lip of trench and place ground pads around work area.
2. Measure trench depth and width.
3. Select suitable size shores and lay out air control system.
4. Assemble 3 sets of timber panels.
5. Install first set of panels as close to subject location as possible.
6. Attach utility rope and air hose to first shore (set up additional shores with rope and air hoses). (continued)

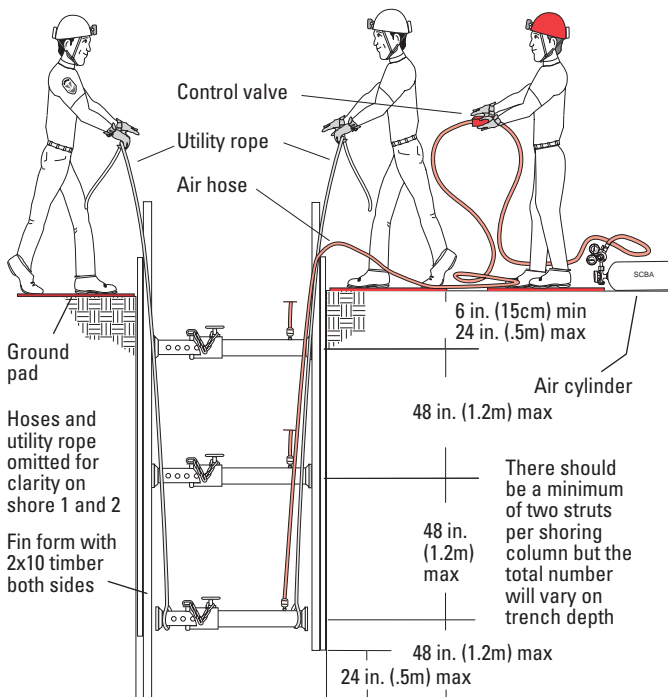

Pneumatic Shore Placement

7. Lower first shore into trench and position between 6 in. (15cm) and 24 in. (61cm) of the lip.
8. Ensure shore is level, then pressurize appropriately.
9. Tie off utility rope to top of panel and place second shore within 48 in. (122cm) of first shore.
10. Place third shore and pressurize.
11. Install second set of panels within 4 ft. (1.2m) on center of first set and repeat shore process.
12. Install third set of panels within 4 ft. (1.2m) on center on the other side of the first set of shores.
13. Set pins on shores and tighten all collars.
14. Nail or screw each shore base plate to timber.

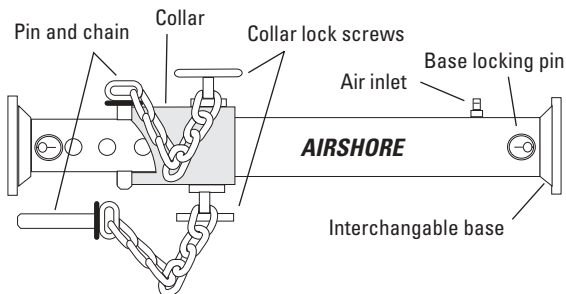

Pneumatic shore key points are

- Install shores from top down or according to manufacturer
- Pressurize to manufacturers specifications per soil conditions
- Tighten collars and screw or nail base to timber
- Always refer to tabulated data provided by the manufacturer for correct spacing

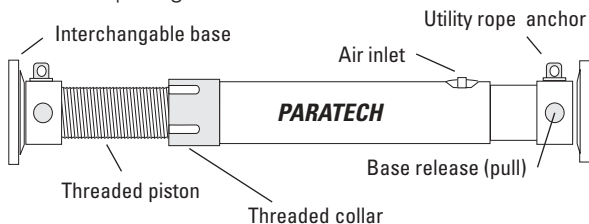

Timber Shore Step-by-Step

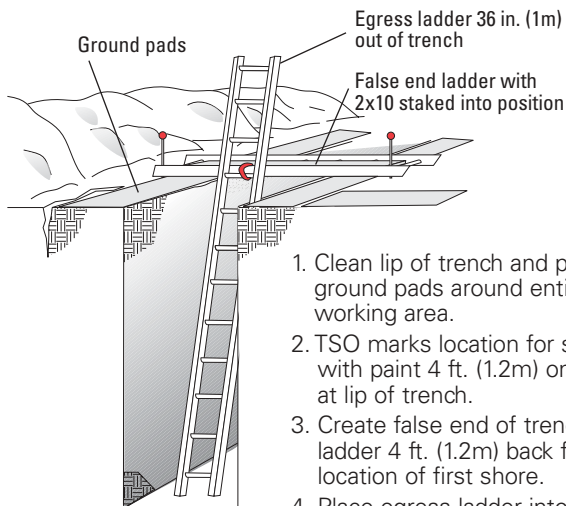

1. Clean lip of trench and place ground pads around entire working area.
2. TSO marks location for shores with paint 4 ft. (1.2m) on center at lip of trench.
3. Create false end of trench with ladder 4 ft. (1.2m) back from location of first shore.
4. Place egress ladder into trench and secure to end ladder.
5. Assemble vertical uprights by placing one piece of form sheeting on top of 2x10 (may be pre-assembled).
6. Position with 1 ft. (.3m) of 2x10 exposed on each end and nail into place.
7. Flip over and nail bottom joist hanger no greater than 2 ft. (.5m) from end.
8. Measure trench and determine best location for last joist hanger so that it will be inside trench.
9. Joist hangers must not be greater than 3 ft. (1m) apart for a trench less than 8 ft. (2.5m) deep.
10. Assemble opposite vertical upright in the same manner but do not put on joist hangers. (continued)

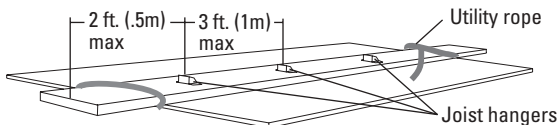

Timber Shore Step-by-Step

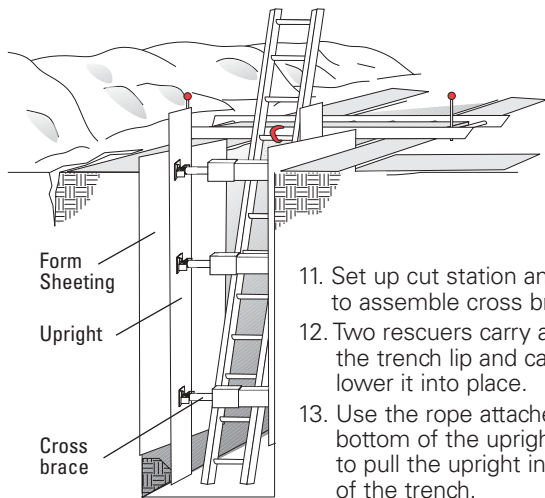

11. Set up cut station and prepare to assemble cross braces.
12. Two rescuers carry an upright to the trench lip and carefully lower it into place.
13. Use the rope attached to the bottom of the upright assembly to pull the upright into the toe of the trench.
14. When both uprights are in position, the builder climbs down the ladder no more than waist deep and measures the distance from upright to upright.
15. The builder calls out the distance in inches and the cut station subtracts 10 in. (25cm) and make the cut.
16. The assembly crew adds the 4x4 to a screw jack and secures it with one nail.
17. A utility rope is clipped to the assembled cross brace and it is handed to the builder.
18. The builder places the 4x4 in the top joist hanger and begins to expand the screw jack.
19. Place a nail in the base of the screw jack to secure it to the upright.
20. Repeat the process from the top down, until all cross braces are in position.
21. A final tightening is done on each cross brace.

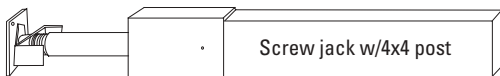

Timber Shore Step-by-Step

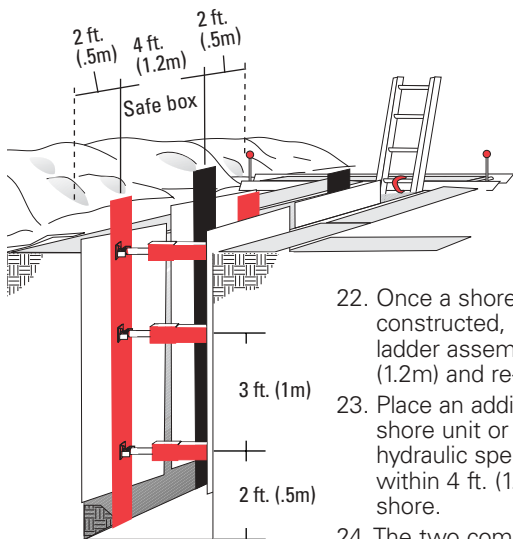

22. Once a shore unit is constructed, move the ladder assembly back 4 ft. (1.2m) and re-secure.
23. Place an additional timber shore unit or an aluminum hydraulic speed shore within 4 ft. (1.2m) of the first shore.
24. The two complete shore units create a safe box that extends 2 ft. (.5m) on either side of the cross brace center.
25. An additional shore unit would extend the safe zone provided it is placed within 4 ft. (1.2m) on center.
26. Once a safe box is constructed, dirt removal and patient stabilization can occur.
27. Move as much dirt laterally as is possible then move dirt vertically with buckets, if required.
28. Use several buckets and only fill half full.
29. Be prepared for crush syndrome (p.151).
30. Focus on patient removal as first priority and ALS treatment as second priority.

✓ You must be prepared to modify timber shore to fit the irregular shape and depth of a collapse area.



Wale System



A wale system is used for protecting intersecting trenches and other difficult to shore locations.

1. Follow all steps required to make the trench safe and to construct protected safe zones for workers to enter the trench.
2. Construct a safe box on all sides of the intersection or area to be protected.
3. Measure distance on center between safe boxes (must not exceed 6 ft. (2m) per engineer specifications).
4. Nail joist hangers on 6x6 wales at specified distance apart.
5. Attach utility rope to each end of wale and lower into trench, feeding between protective system components.
6. Place top wale within 18 in. (.4m) of trench lip (plan ahead).
7. Place second wale within 3 ft. (1m) on center of first wale.
8. Measure distance between wale and opposite vertical upright.
9. Place cross braces as noted in earlier procedure.
10. Slide sheeting between wale and unprotected trench area.
11. This system is for trenches between 5 ft. and 8 ft. (1.5 to 2.5m) deep. Deeper trenches require larger walers 3 ft. (1m) on center up to 11 ft. (3.3m) deep and 2 ft. (.5m) on center between 11 ft. and 15 ft. (3.3 to 4.5m).
12. If trench is too narrow to use screw jacks, use wedges.

✓ **Standing water in trench is inherently unsafe and must be removed prior to shoring.**

Wale Setup

